



101 E

Laminator including Chill Roll Unit

For processing and production of plastic sheets



Consisting of:

- ionization bars
- slewable aluminium reversing rolls
- high-precision polished chill roll
- highly polished chill back-up roll
- frequency controlled individual drive
- edge trimmer
- laminator can be moved in web direction on rails
- hoisting unit for height adjustment of the laminator
- operations area
- switch and control box

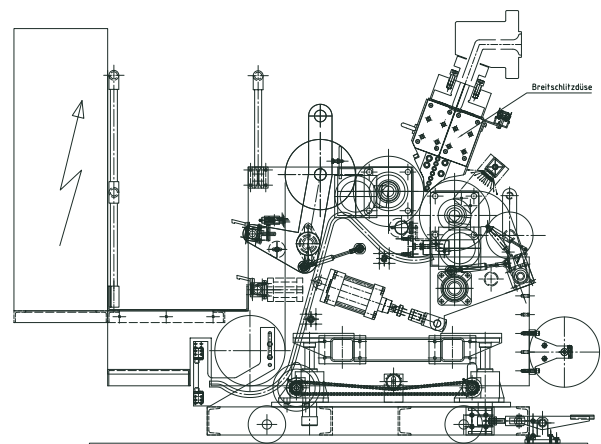

Technical data:

Working width	up to 3.000 mm
Unit speed	up to 100 m/min.
Rotation precision of roll	max. 0,015 mm
Controller	PLC Siemens S7 – 300
Voltage	depending on order