

Preheating- and lamination unit for extrusion

Preheating of web material for lamination process



Preheating unit

- double-walled heating roll (thermal-oil via sealing head)
- driven heating roll
- max. contact surface material to roll
- measurement roll at inlet
- guide roll

Lamination unit

- IR-unit vertical vertical hanging parallel to web material
- IR-unit pneumatic horizontal moveable lamination roller (chromated / gummed) water cooled by sealing head
- gummed lamination roll adjustable via hydraulic cylinder
- lamination rollers easy removable
- manual gap setting
- measuring roll at inlet
- insulated housing with access on backside and side window

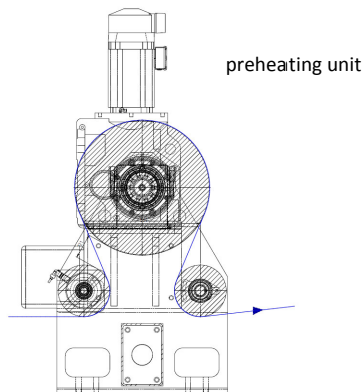
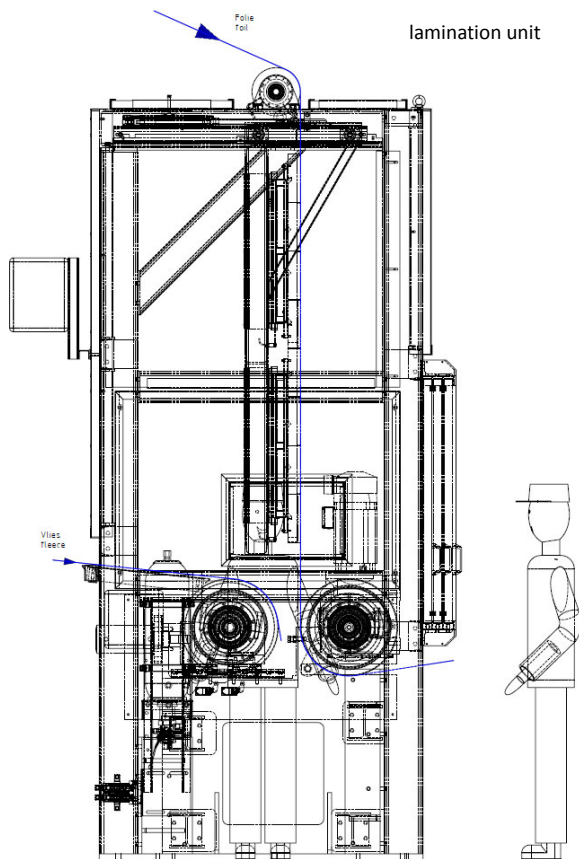

Technical data	
Working width	up to 4.000 mm
Unit speed	up to 60 m/min
Controller	SPS Siemens S7-300